



2019 Lake Pupuke Optimist Team Race sponsored by Thunderbox

2nd & 3rd March, 2019

Lake Pupuke, Auckland, New Zealand

The Organising Authority is the Murrays Bay Sailing Club (MBSC).

SAILING INSTRUCTIONS

[DP] denotes a rule for which the penalty for a breach of that rule, is at the discretion of the protest committee.

[NP] denotes a rule for which for a breach of that rule, will not be grounds for protest by a boat.

[SP] denotes a rule for which a standard penalty may be applied by the race committee without a hearing.

1 RULES

1.1 The regatta will be governed by the rules as defined in *The Racing Rules of Sailing*.

1.2 The Yachting New Zealand Safety Regulations Part 1 shall apply.

Refer - <http://www.yachtingnz.org.nz/racing/safety-regulations>

1.3 Under RRS 86, *Changes to The Racing Rules* the following racing rules will be changed as follows:

- RRS A5, *Scores Determined by the Race Committee*, will be changed to state that when a boat starts and finishes, and breaks RRS 28.1 by failing to sail the course described in the Sailing Instructions, 10 points shall be added to her score without a hearing. [SP]
- RRS A4 and A5 will be changed to state that a boat starting later than 2 minutes after her starting signal will be scored Did Not Start. [SP]

1.4 Appendix D shall apply.

Appendix D 1.1(d), *Arm Signals When Rule 20 Applies*, is deleted.

All races will be umpired. Appendix D 2.5, *Two-Flag Protest Procedure*, and Appendix D 2.6, *Limited Umpiring*, shall not apply.

2 NOTICES TO COMPETITORS

Notices to competitors will be posted on the official notice board located in the marquee on the lawn between the lake and the Silvan Park carpark. In addition, announcements will be made via loudspeaker at the event grounds.

3 CHANGES TO SAILING INSTRUCTIONS

- 3.1 Any change to the sailing instructions will be posted at least 15 minutes before the start of any race to which it applies.
- 3.2 Flag L will be displayed ashore each day until 2 hours after the amendment is made or until another amendment is made.
- 3.3 Any change to the starting time of the first race of the day will be posted by 1800 or within 60 mins after the last race, whichever is the later, on the day before it will take effect.

4 SIGNALS MADE ASHORE

- 4.1 Signals made ashore will be displayed from the main flagpole located in the Silvan Park parking area near the lake shore launching area.
- 4.2 When flag 'AP' is displayed ashore '1 minute' is replaced with 'not less than 15 minutes' in the race signal AP

5 FORMAT

- 5.1 The intended format of the regatta is described in Attachment A. The Organising Authority may at any time change the format, terminate or eliminate any round or stage, when the conditions, remaining time or other relevant factors do not permit the completion of the regatta format.
- 5.2 The scheduled time of the warning signal of the first race on Sat 2nd March is 10:00.
- 5.3 The scheduled time of the warning signal of the first race on Sun 3rd March is 09:00.
- 5.4 On Sunday 3rd March, the last round of the General Round series shall start no later than 12:00.
- 5.4 On Sun 3rd March, no warning signal will be made after 16:00.
- 5.5 Every race will be assigned a race number in the race schedule. The schedule of races will be displayed on the official race tv screens in the Race Control tent. Any changes to the schedule will be displayed not less than 15 minutes before the warning signal of any race concerned.

- 5.6 The Race Committee may decide not to run a re-sail if the result of the race is not relevant to the progression of any team to the next round.

7 RACING AREA

The intended racing area will be on Lake Pupuke near Sylvan Park.

8 THE COURSE

- 8.1 The diagram in Attachment B shows the course, including the approximate angles between legs, the order in which marks are to be rounded, and the side on which each mark is to be left.
- 8.2 Courses will not be shortened. The changes RRS 32.
- 8.3 The Race Committee may move marks of the course at any time. The moving of a mark by the Race Committee shall not be grounds for redress.

9 MARKS

The description of the marks is in the table in Attachment B.

10 OBSTRUCTIONS

The shallow, rocky area near the shore of Sylvan Park and the launching area, as indicated by the line of small orange buoys is designated as an obstruction. Boats shall not cross or sail inside the line of the buoys.

11 THE START

- 11.1 RRS 26, *Starting Races* and related Race Signals will not apply.
- 11.2 The starting line will be between a staff displaying an orange flag on the committee boat at the starboard end of the line and the course side of the port-end starting mark.
- 11.3 The race number will be displayed on the starting committee boat prior to the warning signal for that race. When the race number is displayed in this way it overrides all prior communications, schedules or instructions. The race committee may at any time remove a particular race from the published sequences of races and run it at a later time.
- 11.4 Boats whose warning signal has not been made shall avoid the starting area and course area during the starting sequence for other races.
- 11.5 The starting sequence will be made using flags and sound signals as follows:

Signal	Time	Flags	Sound
Warning	3 mins	3	1 long
Preparatory	2 mins	2	1 short
One-minute	1 min	1	1 short
Start	0	0	1 long

- 11.6 The starting signal of a race may be the warning signal for the following race.
- 11.7 A boat that does not start within 2 minutes after her starting signal shall be scored Did Not Start without a hearing. This changes RRS A4 and A5.
- 11.8 When at a boat's starting signal any part of her hull, crew or equipment is on the course side of the starting line, the race committee shall promptly display code flag 'X' with one sound, and may hail her sail number. The flag shall be displayed until all such boats have sailed completely to the pre-start side of the starting line or its extension, but no later than 1 minute after the starting signal.
- A failure to hail boat numbers correctly, or the order in which boat numbers are hailed, shall not be grounds for redress.

12 THE FINISH

The finishing line will be between a staff displaying a blue flag on the finishing boat at the starboard end of the line and the course side of the port-end finishing mark.

13 UMPIRING

All races will be umpired under the single flag system. RRS Appendix D 2.2 applies.

Appendix D 2.5, *Two-Flag Protest Procedure*, and Appendix D 2.6, *Limited Umpiring*, shall not apply

14 TIME LIMITS AND TARGET TIMES

- 14.1 Time limits and Target Times are as follows:

<i>Target Time</i>	<i>Finish Window</i>	<i>Time Limit</i>
10 mins	5 mins	20 mins

- 14.2 Boats failing to finish within the Finish Window after the first boat sails the course and finishes will be scored Did Not Finish without a hearing. This changes RRS 35, A4 and A5.

15 SCORING

RRS D3 and D4 shall apply.

16 REPLACEMENT OF CREW OR EQUIPMENT

- 16.1 After registration, no team member may be changed without the prior permission of the Organising Authority.
- 16.2 Substitution of damaged or lost equipment will not be allowed unless authorised by the Race Committee.

17 SUPPORT BOATS

No coach or support boats are allowed on the water at Lake Pupuke for the duration of the event.

18 COMMUNICATION

- 18.1 Announcements and communications will be made to competitors via loudspeaker announcement on shore. [DP]
- 18.2 Except in an emergency, a boat that is racing shall not make voice or data transmissions and shall not receive voice or data communication that is not available to all boats. This restriction also applies to mobile telephones. [DP]

19 PRIZES

- 19.1 The following prizes will be awarded;
- 1st Open Fleet Division Team
 - 1st Green Fleet Division Team
- 19.2 Additional prizes may be awarded at the discretion of the Organising Authority.

20 INSURANCE

Each participating boat shall be insured with valid marine third-party liability insurance with a minimum cover of \$500,000 per incident or the equivalent. [DP]

21 DISCLAIMER OF LIABILITY

Competitors participate in the regatta entirely at their own risk. See RRS 4, *Decision to Race*. The organizing authority and any sponsors associated with the event will not accept any liability for material damage or personal injury or death sustained in conjunction with or prior to, during, or after the regatta.

22 RIGHTS TO USE NAME AND LIKENESS

By participating in this event, competitors automatically grant to the Organising Authority and the event sponsors the right, in perpetuity, to make, use, and show, at their discretion, any photography, audio and video recordings, and other reproductions of them made at the venue or on the water from the time of their arrival at the venue, until their final departure, without compensation.

23 USE OF DRONE FOR MEDIA

All those who take part in this event as competitors as well as support crew or spectators agree to be overflown by a drone during the duration of the event, this includes your person and your property (boats).

ATTACHMENT A - RACING FORMAT**1 GENERAL**

- 1.1 The Open teams and the Green teams will race together in the initial Swiss League series of races.
- The Open and Green teams will then be split into separate divisions for their semi-final and final knock-out matches.
- 1.2 The regatta will consist of three stages for each division:
1. Swiss League Series – (Open and Green combined)
 2. Semi-finals – (Open and Green divisions separate)
 3. Finals – (Open and Green divisions separate)

2 STAGE ONE - SWISS LEAGUE SERIES

- 2.1 The first round will consist of an initial series of races using the Swiss League Scoring/Ranking Programme.
- 2.2 Teams will be ranked prior to the first round by the Organising Authority, and these will be used to determine the pairings for the first round.
- 2.3 Thereafter, the Swiss League scoring will pair teams with the same or similar scores against each other. It is unlikely that a team will race against every other team in their division.
- 2.3 The four highest ranked teams in each division at the conclusion of Stage 1 will qualify for Stage 2.

3 STAGE TWO - SEMI-FINALS

- 3.1 The Semi-Final for each division will be a best of 3 knock-out match.
- 3.2 The highest ranked team in each division from Stage 1 will choose their opponent.
- 3.3 The remaining two teams from each division shall race each other.
- 3.4 The first two teams in each division to score at least two wins will qualify for Stage 3.
- 3.5 There will not be any Petite-Final races for the losing teams in each semi-final for either division.

4 STAGE THREE - FINALS

- 4.1 The Final for each division will be a best of 5 knock-out match.
- 4.2 The first team in each division to score at least three race wins will be awarded 1st place and will be crowned the Open Fleet and Green Fleet Lake Pupuke Team Race Regatta Champions.

ATTACHMENT B - COURSE

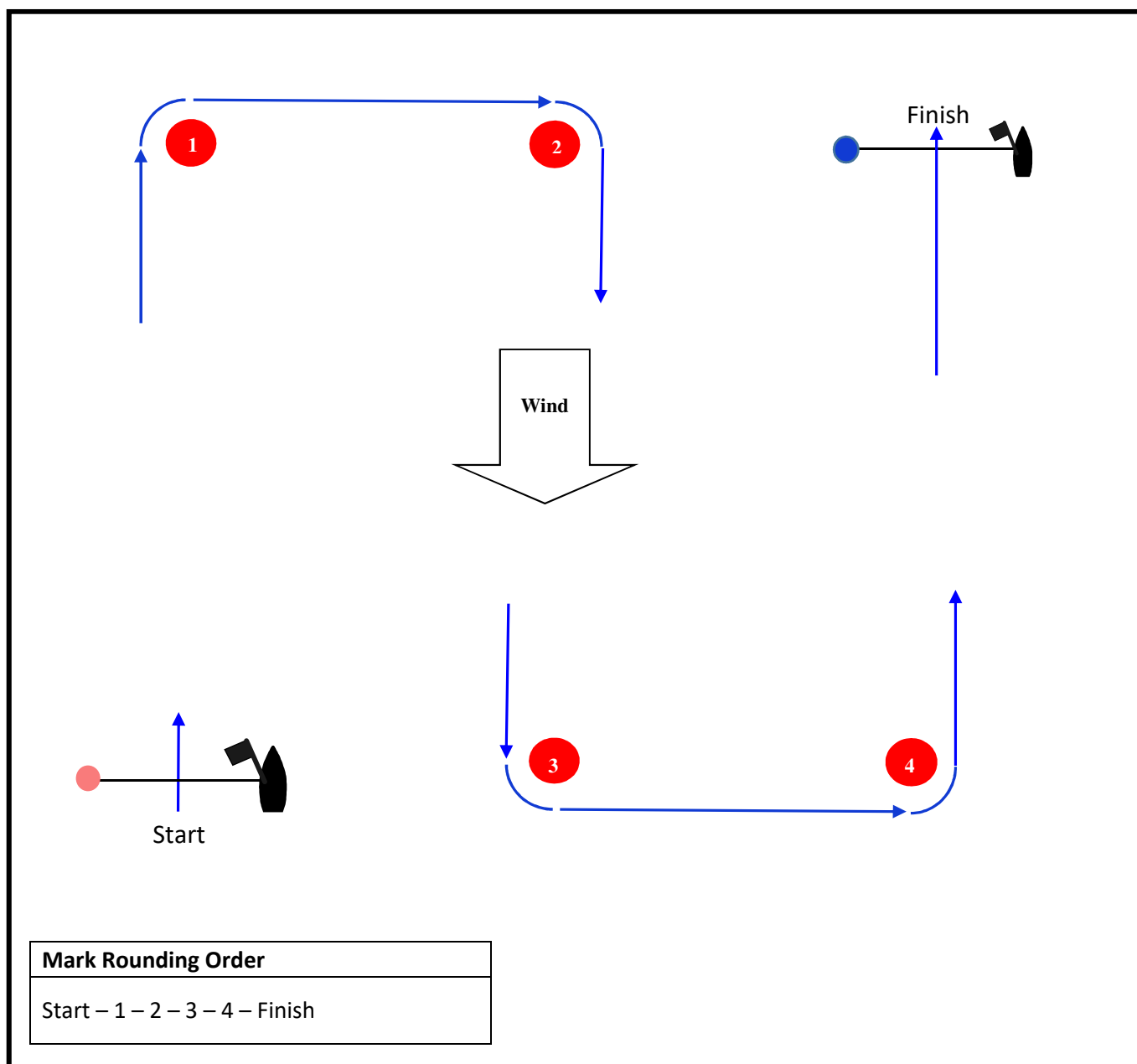

Mark	Description
Mark 1, 2, 3, 4	Large Red/orange cylinders
Starting mark starboard end	Race committee signal boat
Starting mark port end	Large Pink cylinder
Finishing mark starboard end	Race committee rib
Finishing mark port end	Large Blue cylinder

ATTACHMENT C - TEAM IDENTIFICATION

1 GENERAL

- 1.1 Each team will be assigned an alphabetic letter by the Organising Authority.
- 1.2 The team letter will be used to identify teams in the race schedules and scoring.
- 1.3 Letters will be supplied by the Organising Authority.

2 LETTER PLACEMENT

- 2.1 Each team member shall place a letter on each side of their mainsail.
- 2.2 The letters shall be placed on the leech within 100mm of the edge.
- 2.3 The starboard side letter shall be placed immediately below the bottom batten. The port side letter shall be placed below the starboard letter. Letters shall not be placed back-to-back or overlapping.
- 2.4 Refer to diagram below.

