

# STACK WINTER CHAMPS 2020

## 2020 STACK MBSC WINTER CHAMPIONSHIPS Friday 2<sup>nd</sup> – Sunday 4<sup>th</sup> October

The Organising Authority is MURRAYS BAY SAILING CLUB (INC.)  
511 Beach Road, Murrays Bay, Auckland 0630

### SUPPLEMENTARY SAILING INSTRUCTIONS (SSI)

This sheet and Attachment A are supplements to Appendix S of the Racing Rules of Sailing (page 136 RRS 2017-2020).

#### RULES

- SSI 1** (i) For all fleets, Appendix T, Arbitration, will apply.  
(ii) RRS P5, Flags O and R, shall apply where class rules permit. In all other respects Appendix P, Special Procedures for Rule 42, will not apply.

#### NOTICES TO COMPETITORS (SI 2)

- SSI 2** The race office is located at Murrays Bay Sailing Club. Notices to competitors will be placed on the official notice board at [www.murraysbay.org/2020-stack-winter-championships/](http://www.murraysbay.org/2020-stack-winter-championships/).

#### SIGNALS MADE ASHORE (SI 4)

- SSI 3** Signals ashore will be displayed on the flagstaff located at Murrays Bay Sailing Club.  
**SSI 4** A boat shall not leave the shore until flag D is displayed. The warning signal will be made not less than 30 minutes after flag D is displayed or not before the scheduled time, whichever is the later. When flag AP is displayed ashore, “1 minute” is replaced by “not less than 30 minutes” in the race signal AP. This changes SI 4.2

**SSI 5** When a visual signal is displayed over a fleet(s) or course(s) flag, the signal applies only to that fleet(s) or course(s). This changes Race Signals preamble.

#### **SCHEDULE OF RACES AND CLASS FLAGS (SI 5 & 6)**

<b>Day/Date</b>	<b>Course</b>	<b>Number of Races</b>	<b>Time of first warning signal</b>	<b>Class</b>
Friday 2 <sup>nd</sup> October	A	3	1100	Optimist White/Open
		3	1200	Optimist Green, O'pen Skiff, P Class
	B	3	1100	Starling, Laser Radial
		3	1200	RS Feva, 420, 29er
Saturday 3 <sup>rd</sup> October	A	3	1100	Optimist White/Open
		3	1200	Optimist Green, O'pen Skiff, P Class
	B	3	1100	Starling, Laser Radial
		3	1200	RS Feva, 420, 29er
	D	4	1100	49er, 49erFX, Windfoil
	Sunday 4 <sup>th</sup> October	A	3	1000
3			1100	Optimist Green, O'pen Skiff, P Class
B		3	1000	Starling, Laser Radial
		3	1100	RS Feva, 420, 29er
D		4	1000	49er, 49erFX, Windfoil

**SSI 6** On Sunday 4<sup>th</sup> October no warning signal will be made after 1500.

#### **COURSES (SI 7)**

**SSI 7** The courses to be sailed, the order in which the marks are to be passed, and the side on which each mark is to be left are shown in Attachment A.

#### **MARKS (SI 8)**

**SSI 8** The description of the marks is below each course diagram.

#### **THE START (SI 9)**

**SSI 9** The starting line will be between a staff displaying an orange flag on the race committee vessel and the course side of the starting mark, or if the port end starting mark is a vessel, the staff on it displaying an orange flag. This changes SI 9.2.

**SSI 10** To alert boats that a race or sequence of races will begin soon, the orange starting line flag will be displayed with one sound at least five minutes before a warning signal is made.

**SSI 11** When a starting sequence is in progress, boats whose warning signal has not been made shall avoid the starting area. The starting area is defined as the area 50 metres from the starting line and marks in all directions.

**SSI 12** A boat starting later than four minutes after her starting signal will be scored Did Not Start without a hearing. This changes RRS A4.1.

## TIME LIMITS (SI 12)

Course/Class	Target time for first finisher	Finish Window	Race Time Limit
Course A/Optimist Green	30 minutes	15 minutes	60 minutes
Course A/Optimist Open, O'pen Skiff, P Class	40 minutes	15 minutes	70 minutes
Course B/Starling, Laser Radial, RS Feva, 420	40 minutes	15 minutes	70 minutes
Course B/29er	30 minutes	15 minutes	45 minutes
Course D/49er, 49erFX, Windfoil	20 minutes	15 minutes	30 minutes

There is no prescribed time limit for the first boat to pass mark 1.

## SCORING

**SSI 13** For the Optimist Green, Optimist Open, O'pen Skiff, and P Class fleets, boats failing to finish within the Finish Window after the first boat in its fleet sails the course and finishes will be scored SRS, "Still Racing Score". This changes SI 12.3 and NOR 1.3. This score will be 3 points more than the last boat to finish in the fleet of that race but not more than DNF. The Race Committee may award a boat still racing a place on the water even though that boat may not have completed the course. Any such place shall be higher than those boats that have completed the course. The Race Committee shall notify the boat(s) concerned at the time, and may instruct the boat to return to the starting area or go ashore.

## PENALTY SYSTEM

**SSI 14** For skiff classes including the RS Feva rule RRS 44.1, Taking a Penalty, is changed so that the Two-Turns Penalty is replaced by the One-Turn Penalty.

**SSI 15** For the Windfoil class B44.4 WCR shall apply: If an infringement is acknowledged by a competitor, they shall complete a One-Turn Penalty clear of any other competitor; or alternatively, a competitor may elect a Scoring Penalty of two (2) points in lieu of completing a One-Turn Penalty (B44.4 WCR).

## CHECK OUT AND CHECK IN

**SSI 16** Boats shall comply with the following check-out and check-in procedure:

- a) The official check-out and check-in sheets will be located adjacent to the ramp.
- b) Competitors shall individually check out before racing by personally recording their sail number, name and signature on the check-out sheets. Failure to legibly complete the check-out sheet may result in the competitor being scored DNC for all races that day. [DP].
- c) A competitor retiring from racing shall notify the Race Committee before leaving the racing area, or if that is not possible, shall notify the race office as soon as possible on returning to shore. [DP]

## **SUPPORT VESSELS**

- SSI 17** Except when participating in rescue operations, coaches, parents and other support personnel shall stay outside areas where boats are racing from the time of the preparatory signal for the first fleet to start until all boats have finished or retired or the Race Committee signals a postponement or an abandonment (but not a general recall) of all fleets.
- SSI 18** When a Race Committee member indicates a support vessel to move further from the course area, the mentioned vessel shall do so immediately.
- SSI 19** All support vessels shall have a kill-cord attached to the driver at all times while the engine is running.

**END**

# 2020 STACK WINTER CHAMPIONSHIPS

## APPENDIX A: Course Illustration – Course A

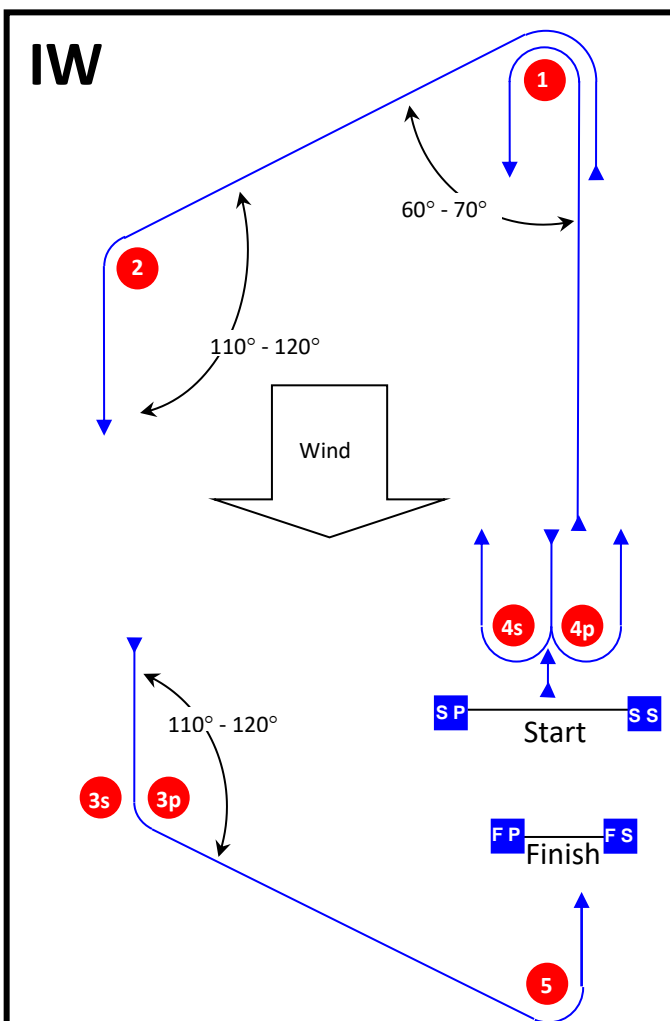

**Course: Inner Trapezoid with beat to finish**

Signal	Mark Rounding Order
<b>IW2</b>	Start – 1 – 4s/4p – 1 – 2 – 3p – 5 – Finish
<b>IW3</b>	Start – 1 – 4s/4p – 1 – 4s/4p – 1 – 2 – 3p – 5 – Finish

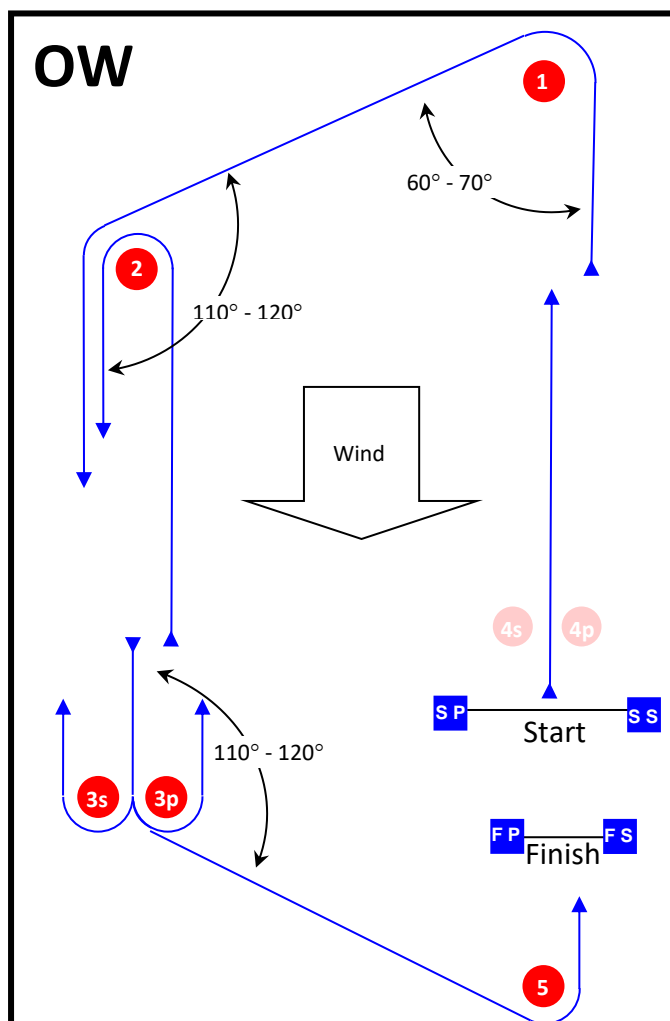

**Course: Outer Trapezoid with beat to finish**

Signal	Mark Rounding Order
<b>OW1</b>	Start – 1 – 2 – 3p – 5 – Finish
<b>OW2</b>	Start – 1 – 2 – 3s/3p – 2 – 3p – 5 – Finish
<b>OW3</b>	Start – 1 – 2 – 3s/3p – 2 – 3s/3p – 2 – 3p – 5 – Finish

Mark	Description
<b>1 2</b>	Red cylinder
<b>3s 3p</b>	Red cylinder
<b>4s 4p</b>	Orange teardrop buoy
<b>5</b>	Red cylinder
<b>SS</b> Starting mark starboard end	Race committee boat
<b>SP</b> Starting mark port end	Race committee boat
<b>FS</b> Finishing mark starboard end	Race committee boat
<b>FP</b> Finishing mark port end	Orange teardrop buoy
Change of course mark	Lime green conical buoy

# 2020 STACK WINTER CHAMPIONSHIPS

## APPENDIX A: Course Illustration – Course B

### IW/L

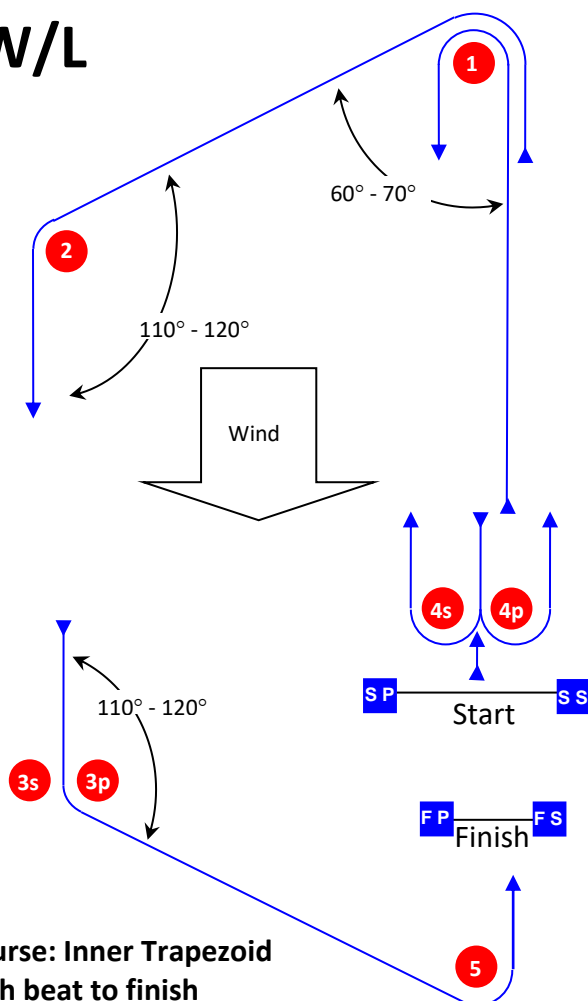

**Course: Inner Trapezoid with beat to finish**

Signal	Mark Rounding Order
L2	Start – 1 – 4s/4p – 1 – 5 – Finish
L3	Start – 1 – 4s/4p – 1 – 4s/4p – 1 – 5 – Finish
IW2	Start – 1 – 4s/4p – 1 – 2 – 3p – 5 – Finish
IW3	Start – 1 – 4s/4p – 1 – 4s/4p – 1 – 2 – 3p – 5 – Finish

### OW

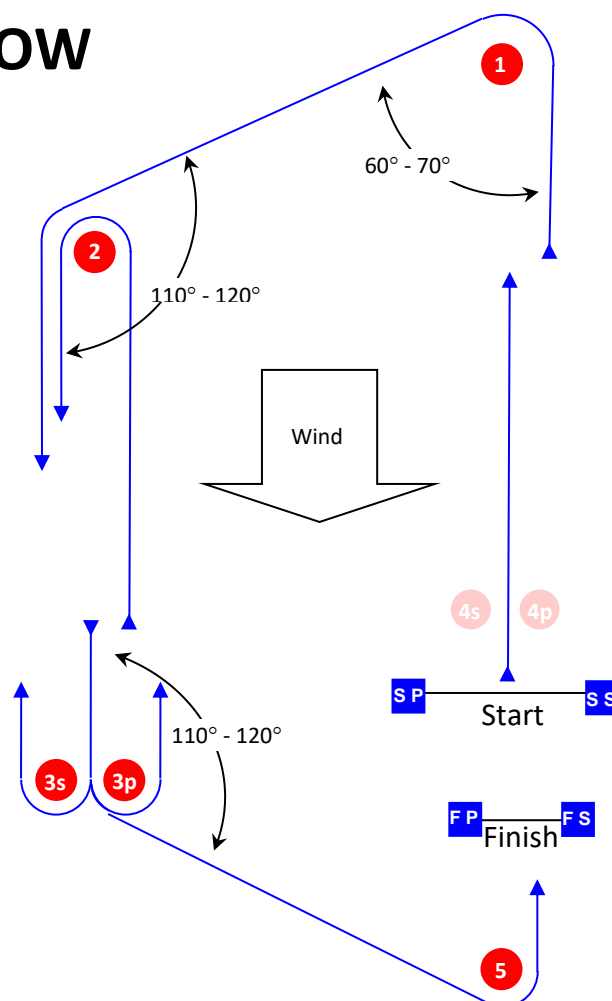

**Course: Outer Trapezoid with beat to finish**

Signal	Mark Rounding Order
OW1	Start – 1 – 2 – 3p – 5 – Finish
OW2	Start – 1 – 2 – 3s/3p – 2 – 3p – 5 – Finish
OW3	Start – 1 – 2 – 3s/3p – 2 – 3s/3p – 2 – 3p – 5 – Finish

Mark	Description
1 2	Orange cylinder
3s 3p	Orange cylinder
4s 4p	Orange teardrop buoy
5	Orange cylinder
SS Starting mark starboard end	Race committee boat
SP Starting mark port end	Orange cylinder
FS Finishing mark starboard end	Race committee boat
FP Finishing mark port end	Orange teardrop buoy
Change of course mark	Lime green conical buoy

# 2020 STACK WINTER CHAMPIONSHIPS

## APPENDIX A: Course Illustration – Course D

**LR**

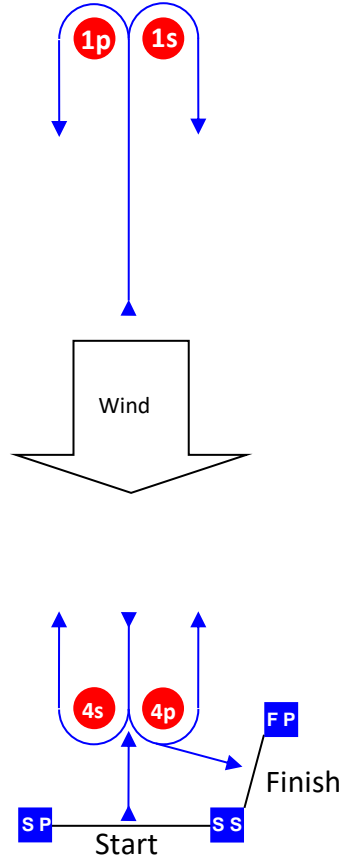

**Course: Leeward finish**

Signal	Mark Rounding Order
<b>LR2</b>	Start – 1s/1p – 4s/4p – 1s/1p – 4p – Finish
<b>LR3</b>	Start – 1s/1p – 4s/4p – 1s/1p – 4s/4p – 1s/1p – 4p – Finish
<b>LR4</b>	Start – 1s/1p – 4s/4p – 1s/1p – 4s/4p – 1s/1p – 4s/4p – 1s/1p – 4p – Finish

Mark	Description
<b>1s 1p</b>	Red cylinder (AON)
<b>4s 4p</b>	Red cylinder (AON)
<b>SS</b> Starting mark starboard end	Race committee boat
<b>SP</b> Starting mark port end	Red cylinder
<b>FS</b> Finishing mark starboard end	Race committee boat
<b>FP</b> Finishing mark port end	Orange teardrop buoy
Change of course mark	Lime green conical buoy