



2023 MBSC ICEBREAKER

Saturday 16th September, 2023

Murrays Bay, Auckland, New Zealand

The Organising Authority is the Murrays Bay Sailing Club (MBSC)
511 Beach Road, Murrays Bay, Auckland, New Zealand.

SUPPLEMENTARY SAILING INSTRUCTIONS (SSI)

This sheet, including attachments, is a supplement to Appendix S of the Racing Rules of Sailing (*page 146 RRS 2021-2024*).

1 RULES

- 1.1 The event is governed by the rules as detailed in the Notice of Race ('NoR') 1.
- 1.2 RRS 40.1, *Personal Flotation Devices*, shall apply at all times while afloat.
- 1.3 Appendix T, *Arbitration* shall apply.

2 NOTICE TO COMPETITORS (SI 2)

- 2.1 The race office is located in the tower on the top floor of the Murrays Bay Sailing Club clubrooms.
- 2.2 The official notice board will be located on the main floor of the Murrays Bay Sailing Club clubrooms.
- 2.3 The online official notice board is located at www.murraysbay.org

3 SIGNALS MADE ASHORE (SI 4)

- 3.1 Signals made ashore will be displayed on the flagstaff located in front of the clubrooms.
- 3.2 When flag AP is displayed ashore, "1 minute" is replaced with "not less than 20 minutes" in Race Signals AP.
- 3.3 [DP] Flag D with one sound signal means "Boats shall not leave the shore until this signal is made. The warning signal will not be made before the scheduled time or less than 20 minutes after flag D is displayed."

4 SCHEDULE OF RACES and CLASS FLAGS

4.1 *Schedule:*

Class	Number of Races	Time of First Warning
All classes	4	11:55



4.2 *Class Flags:*

Class	Class Flag
Optimist Green	Black Optimist symbol on Green background
Optimist Open	Black Optimist symbol on White background
P-Class	Black P logo on White background
O'pen Skiff	Open Skiff flag
Starling Development	Green with Red Star
Starling	Red Star on White background
RS Feva	RS Feva
Laser Radial	Red Laser symbol on Blue background
Laser	Red Laser symbol on White background
420	420
470	470
29er	29er
Waszp	Waszp

4.3 On Saturday 16th September, no warning signal will be made after 16:00.

5 COURSES (SI 7)

- 5.1 The courses to be sailed, the order in which the marks are to be passed, and the side on which each mark is to be left are shown in Attachment A.
- 5.2 In the event that a gate mark is missing and has not been replaced with an object displaying flag M, the remaining gate mark shall be rounded to port.

6 MARKS (SI 8)

6.1 The description of the marks is below the course diagrams in Attachment A.

7 THE START (SI 9)

- 7.1 When a starting sequence is in progress, boats whose warning signal has not been made shall avoid the starting area. The starting area is defined as the area 50m from the starting line and marks in all directions.
- 7.2 A boat starting more than four minutes after her starting signal will be scored Did Not Start (DNS) without a hearing. This changes RRS A5.1 and 5.2.

8 TIME LIMITS (SI 12)

8.1

Course/Class	Target time for first finisher	Finish Window	Race Time Limit
Course A/Optimist Green	30 minutes	15 minutes	60 minutes
Course A/Optimist Open, O'pen Skiff, P Class	40 minutes	15 minutes	70 minutes



ICEBREAKER – 2023

Course B/Starling, Laser Radial, RS Feva, 420	40 minutes	15 minutes	70 minutes
Course B/29er	30 minutes	15 minutes	45 minutes
Course D/49er, 49erFX, Windfoil	20 minutes	15 minutes	30 minutes

8.2 There is no prescribed time limit for the first boat to pass mark 1. Appendix S, SI 12.2 is deleted.



9 PENALTY SYSTEM

- 9.1 For the 29er class RRS 44.1 is changed so that the *Two-Turns Penalty* is replaced with the *One-Turn Penalty*.
- 9.2 For the Waszp class RRS 44.1 is changed so that the *Two-Turns Penalty* is replaced with a *Part-Turn Penalty*.

A *Part-Turn Penalty* is defined as follows:

- (a) When on a leg of the course to a windward mark, she shall gybe and, as soon as reasonably possible, luff to a close-hauled course.
- (b) When on a leg of the course to a leeward mark or the finishing line, she shall tack and, as soon as reasonably possible, bear away to a course that is more than ninety degrees from the true wind

10 PROTEST AND REQUESTS FOR REDRESS

- 10.1 Immediately after finishing a boat intending to protest shall, in addition to the requirements of rule 61.1(a), inform the race committee boat at the finishing line of her intention to protest and the identity of the boat(s) being protested. The protesting boat must receive an acknowledgement from the race committee. This changes RRS 61.

11 SAFETY REGULATIONS

- 11.1 [DP] Boats not leaving the shore for a scheduled race shall promptly notify the race office.
- 11.2 [DP] The official Check-Out and Check-In Sheets will be located adjacent to the ramp and will be overseen by a member of the Race Committee.
- (a) Competitors shall individually check-out before racing by personally providing their sail number and name to the member of the Race Committee overseeing the check-out sheets. Failure to complete Check-out may result in the competitor being scored DNC for all races that day.
- (b) Competitors shall individually check-in immediately on returning to shore after racing, no later than the protest time limit by personally signing the check-in sheets. Failure to complete Check-in may result in the competitor being scored DNC for all races that day.
- 11.3 [DP] A boat retiring from racing shall notify the Race Committee before leaving the racing area, or if that is not possible, shall notify the race office as soon as possible after returning ashore.

12 REPLACEMENT OF CREW OR EQUIPMENT

- 12.1 [DP] Substitution of competitors is not allowed without the prior written approval of the Protest Committee.
- 12.2 [DP] Substitution of damaged or lost equipment is not allowed unless authorised in writing by the Protest Committee. Requests for substitution shall be made to the committee at the first reasonable opportunity, which may be after the race.

13 EQUIPMENT AND MEASUREMENT CHECKS

- 13.1 A boat or equipment may be inspected at any time for compliance with the class rules, Notice of Race and Sailing Instructions.



ICEBREAKER – 2023

- 13.2 [DP] When instructed by a race official on the water, a boat shall proceed to a designated area for inspection.

14 SUPPORT BOATS

- 14.1 [DP] All support boats must register with the Organising Authority at registration and nominate the boat(s) they support.
- 14.2 [DP] All support and coach boats must have VHF communications and be available to assist the race committee if required.
- 14.3 [DP] All support and coach boats shall have an engine safety cut out switch (kill cord) attached to the driver at all times while the engine is running, unless prior written exemption has been provided by the Organising Authority.
- 14.4 [DP] Except when requested to participate in rescue operations, team support boats and other support persons shall stay outside areas where boats are racing and are restricted to a 5 knot speed limit, from the time of the preparatory signal until all boats have finished or the race committee signals a postponement or abandonment of all races. The areas the boats are racing in is defined as the area inside the course and within 100 metres of any mark, lay line, starting line, finishing line or any area where any boat that is racing, is sailing or may sail.

15 FURTHER INFORMATION

For further information please contact;

Web-site	www.murraysbay.org
Address	511 Beach Road Murrays Bay PO Box 65-076 Mairangi Bay
Phone	021 242 6272
Nigel Soper (Club Manager)	mbsc.manager@gmail.com



ATTACHMENT A

Course Illustration - Windward-Leeward

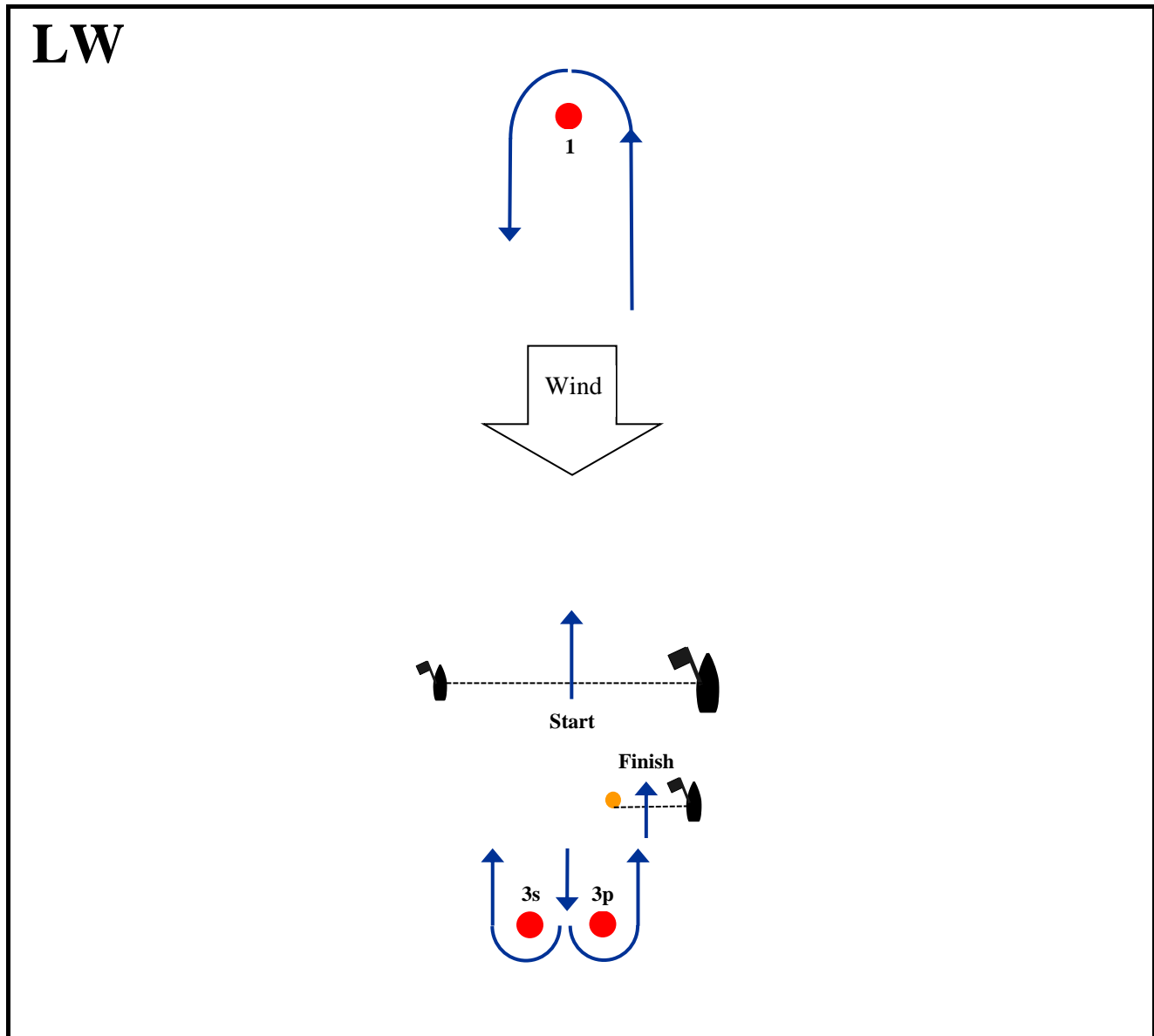

Signal	Mark Rounding Order
LW 1	Start – 1 – 3s/3p – Finish
LW 2	Start – 1 – 3s/3p – 1 – 3s/3p – Finish
LW 3	Start – 1 – 3s/3p – 1 – 3s/3p – 1 – 3s/3p – Finish
Mark	Description
1, 3s/3p	Large tall red cylinder
Start mark – Stbd end	Race committee boat – large launch
Start mark – Port end	Race committee boat – Brin Wilson or small rib
Finish mark – Stbd end	Race committee boat – large launch
Finish mark – Port end	Small orange teardrop
Change Mark	Large tall yellow cylinder



Course Illustration - Triangle - Windward-Leeward

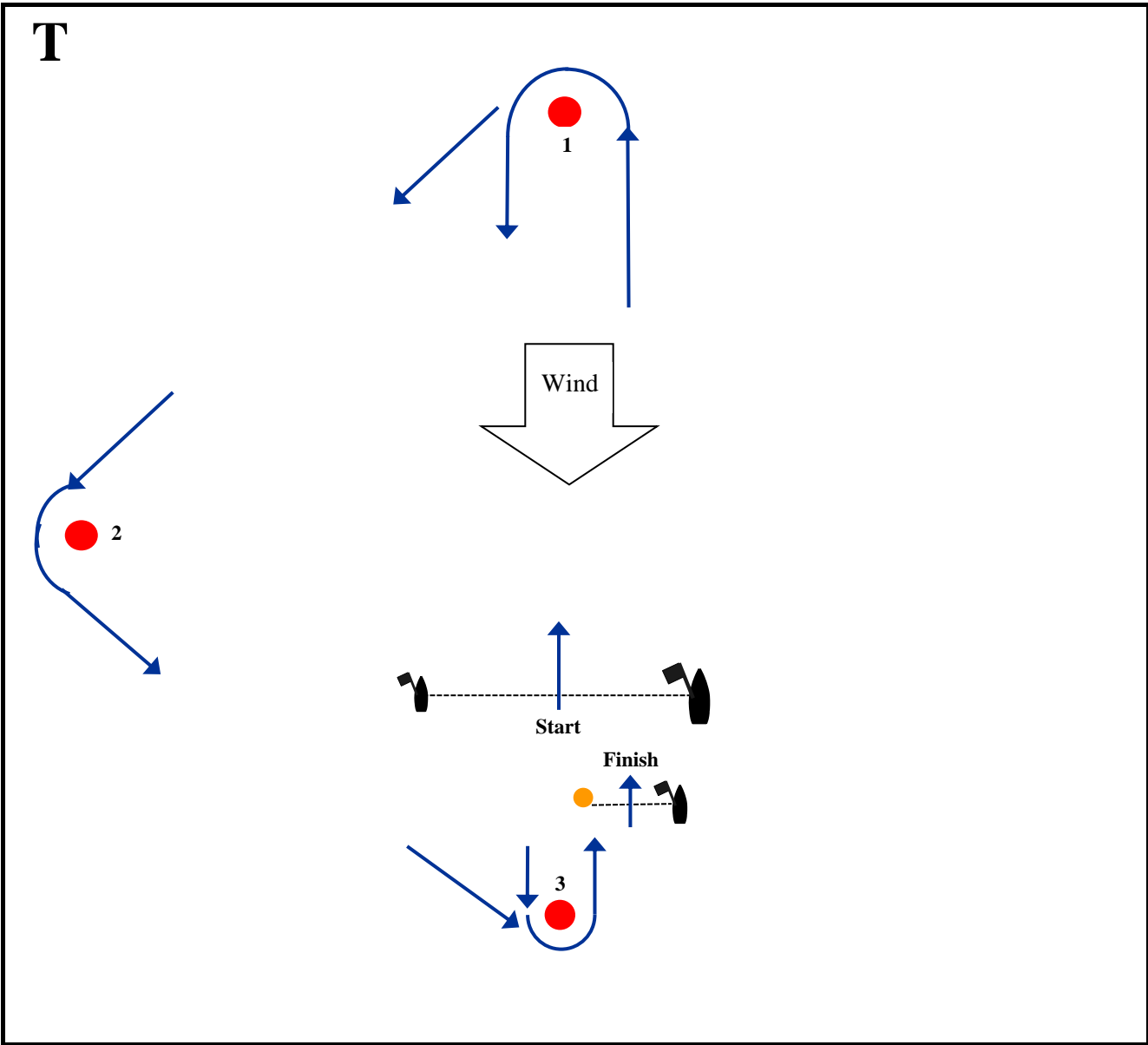

Signal	Mark Rounding Order
T 1	Start – 1 – 2 – 3 – Finish
T 2	Start – 1 – 2 – 3 – 1 – 3 – Finish
T 3	Start – 1 – 2 – 3 – 1 – 3 – 1 – 3 – Finish

Mark	Description
1, 2, 3	Large tall red cylinder
Start mark – Stbd end	Race committee boat – large launch
Start mark – Port end	Race committee boat – Brin Wilson or small rib
Finish mark – Stbd end	Race committee boat – large launch
Finish mark – Port end	Small orange teardrop
Change Mark	Large tall yellow cylinder

Course Illustration – Trapezoid with beat to finish - separate finish

IW

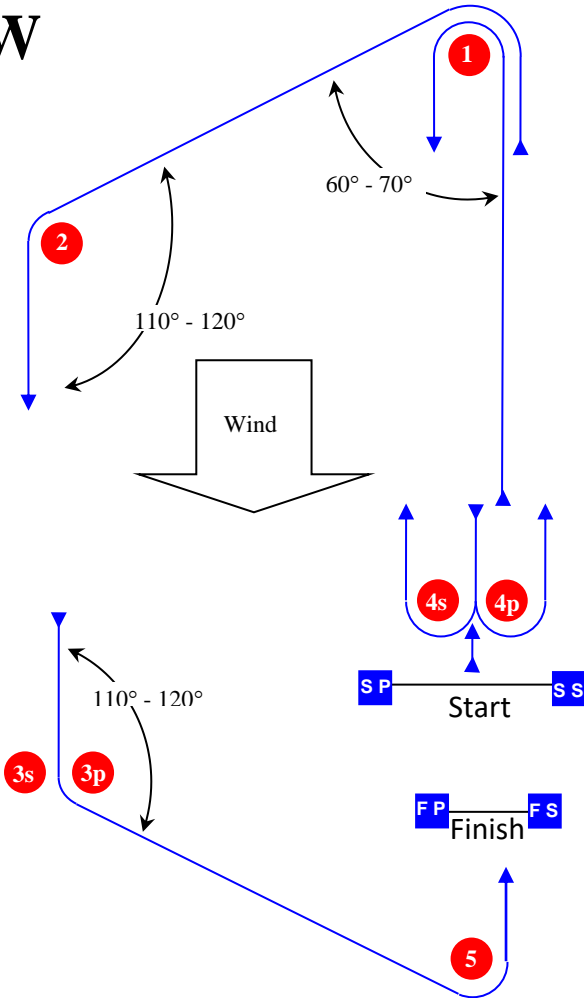

Course: Inner Trapezoid with beat to finish

Signal	Mark Rounding Order
IW1	Start – 1 – 2 – 3p – 5 – Finish
IW2	Start – 1 – 4s/4p – 1 – 2 – 3p – 5 – Finish
IW3	Start – 1 – 4s/4p – 1 – 4s/4p – 1 – 2 – 3p – 5 – Finish
IW4	Start – 1 – 4s/4p – 1 – 4s/4p – 1 – 4s/4p – 1 – 2 – 3p – 5 – Finish

OW

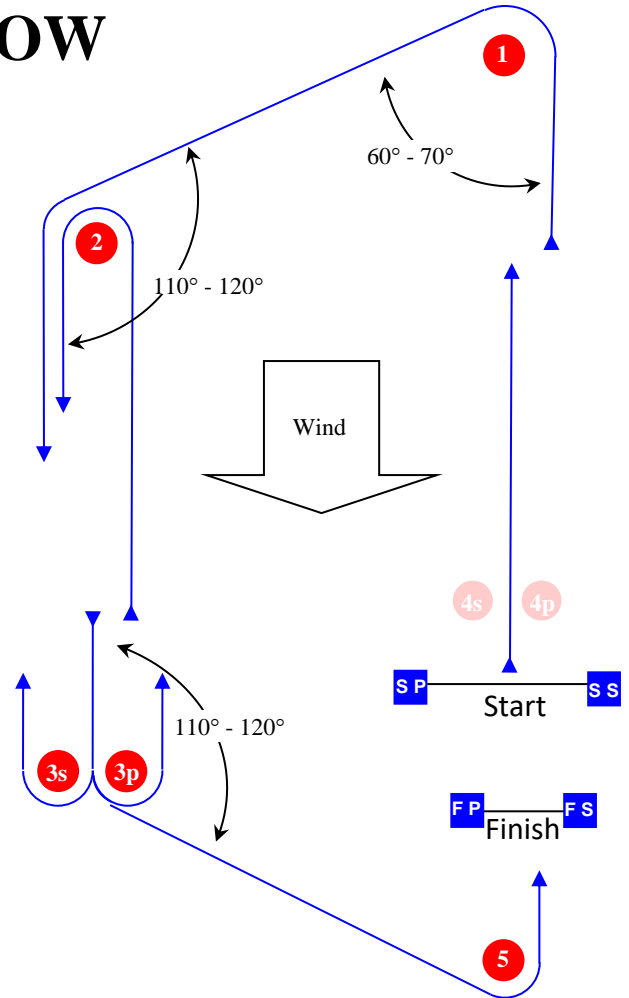

Course: Outer Trapezoid with beat to finish

Signal	Mark Rounding Order
OW2	Start – 1 – 2 – 3s/3p – 2 – 3p – 5 – Finish
OW3	Start – 1 – 2 – 3s/3p – 2 – 3s/3p – 2 – 3p – 5 – Finish
OW4	Start – 1 – 2 – 3s/3p – 2 – 3s/3p – 2 – 3s/3p – 2 – 3p – 5 – Finish

Mark	Description
1 2 3s 3p	Large red/orange cylinders
1a 2a	Large green cylinders
4s 4p	Large red cylinders
5	Large red cylinders
SS Starting mark starboard end	Race committee boat
SP Starting mark port end	
FS Finishing mark starboard end	MBSC rib
FP Finishing mark port end	Small orange teardrop